

# Installation Guide - Jaguar Wall

---



Please read these instructions carefully before commencing installation and retain for future reference. If in doubt, we advise that you consult a qualified electrician to install the product. These products must not be modified, if modification is made or product is not installed with these installation instructions it will invalidate the warranty and may render the product

## Warning

---

1. For indoor use only.
2. If cable is defective, do not use or exchange the cable.
3. The light source of this luminaire is not replaceable; when the light source reaches its end of life the whole luminaire will need to be replaced.
4. We do recommend that a qualified electrician should be used to install the product.
5. Install in accordance with IEE Wiring regulations and current Building Regulations.
6. This light fitting should be connected to a fused circuit
7. If replacing an existing fitting, make a careful note of the

## Important safety Notes

---

1. Switch off the electricity at the mains before commencing installation and remove the appropriate circuit fuse to avoid accidental switching on of the mains supply.
2. Make sure all connections are tight with no loose strands.
3. Ensure fire regulations are not breached when fitting your

## Energy Rating

---

This product contains a light source with an energy rating of **C**

## Installation - Wall

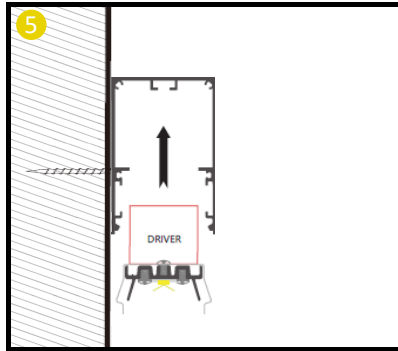
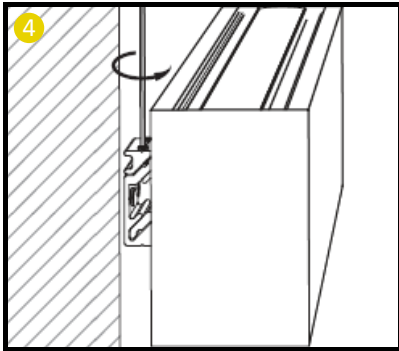
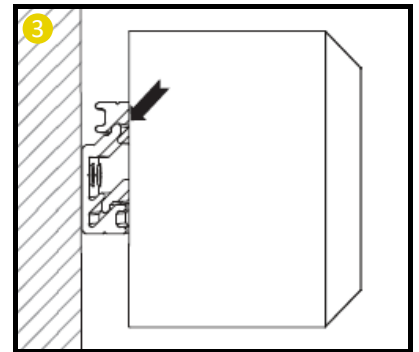
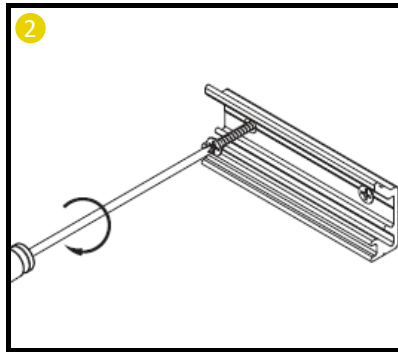
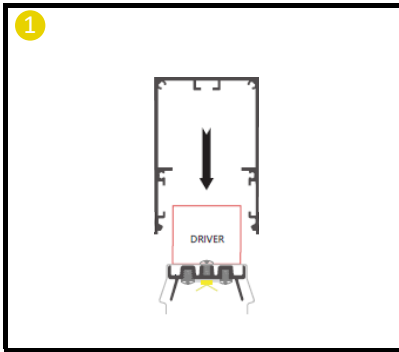

1. Remove the diffuser from the Jaguar profile and the internal geartray.
2. Using the Jaguar luminaire as a template, measure the desired fixing centers on the side of the luminaire where the brackets are mounted (centers will vary depending on product length). Mark these dimensions on to the surface desired and use the appropriate fixing for the substrate. Note: typical centers are product length minus 120mm each end.
3. Offer up the luminaire to the wall mounted brackets in a hooking motion, ensuring the luminaire brackets have housed correctly before allowing the brackets to weight bear. Ensure the power flex has fed through the cable entry correctly on the luminaire housing.
4. Using a long shafted hand tool, lock the bracket in place from above.
5. Terminate the geartray to the power flex (see wiring diagram overleaf), replace the geartray and diffuser.

# Wiring

## Standard



## DALI (-DA)

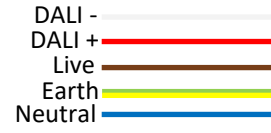

## Standard EM (-E1)

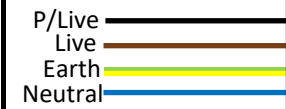

## DALI EM (-E3)

